

# Prisma15

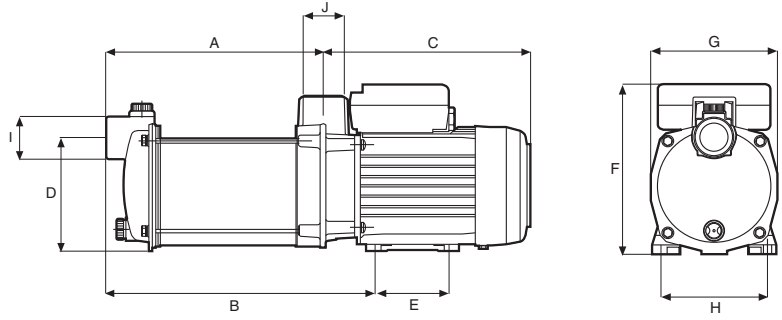

	A	B	C	D	E	F	G	H	I	J	Kg
<b>Prisma15 2</b>	163	213	202	110	74	162	121	102	1"	1"	8.3
<b>Prisma15 3</b>	187	237	202	110	74	162	121	102	1"	1"	9.2
<b>Prisma15 4</b>	211	261	202	110	74	162	121	102	1"	1"	10
<b>Prisma15 5</b>	235	285	202	110	74	162	121	102	1"	1"	11

**Curvas de funcionamiento a 2900 r.p.m.**  
**Performance curves at 2900 r.p.m.**

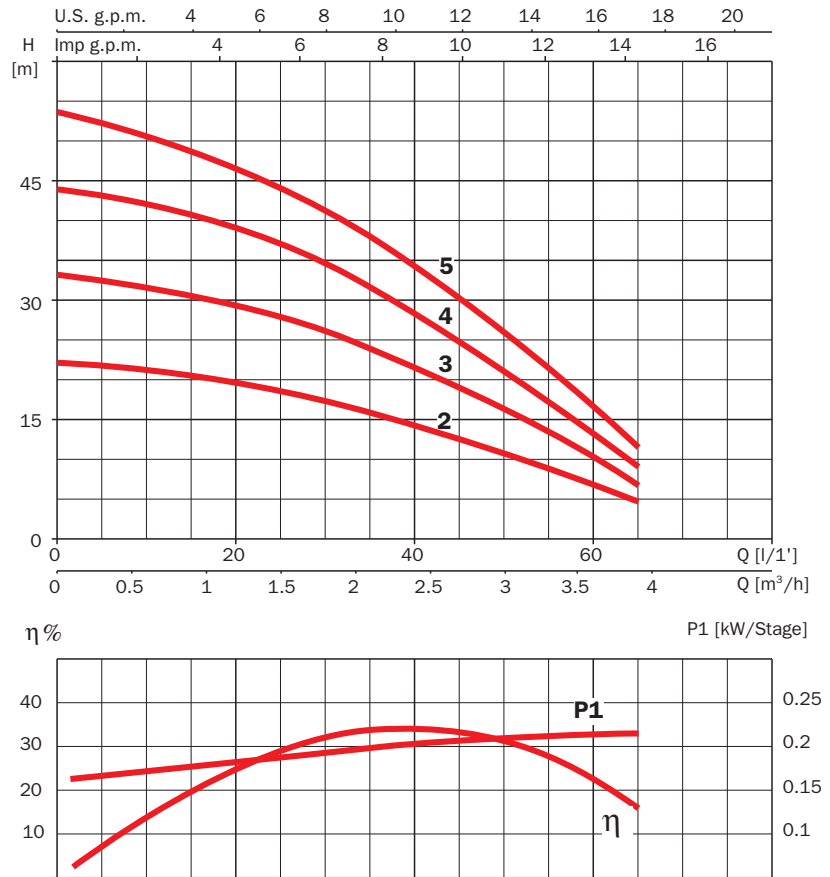

230 V 50 Hz	230/400 V 50 Hz	A			P1 (kW)		kW	HP	μF	L/1'	10	20	30	35	40	50	60	65
		1~ 230 V	3~ 230 V 400 V		1~	3~												
<b>Prisma15 2M</b>		2			0.45	0.46	0.24	0.33	12		21	20	16.5	16	14	10.5	7	5
<b>Prisma15 3M</b>	<b>Prisma15 3</b>	2.74	2.1	1.21	0.61	0.61	0.37	0.5	12		32	30	26	24	22	17	10.5	7
<b>Prisma15 4M</b>	<b>Prisma15 4</b>	3.53	2.3	1.3	0.79	0.7	0.55	0.75	12		43	39	35	32	27	21.5	14	9
<b>Prisma15 5M</b>	<b>Prisma15 5</b>	4.13	3.3	1.9	0.95	0.94	0.75	1.0	12		51	47	42	38	34	25	17	12