

Drainex 100

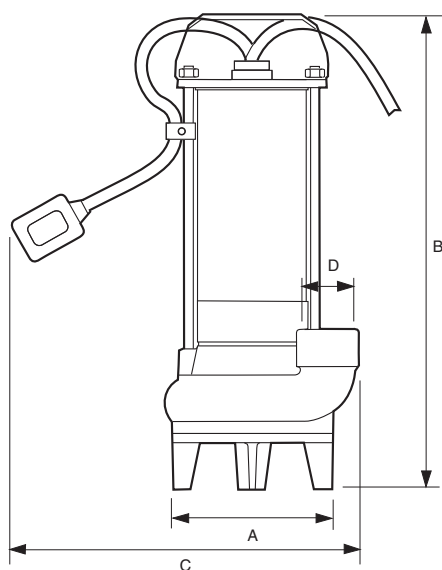

	A	B	C	D	Kg
Drainex 100	138	407	300	1 1/4"	11

Curvas de funcionamiento a 2900 r.p.m.
Performance curves at 2900 r.p.m.

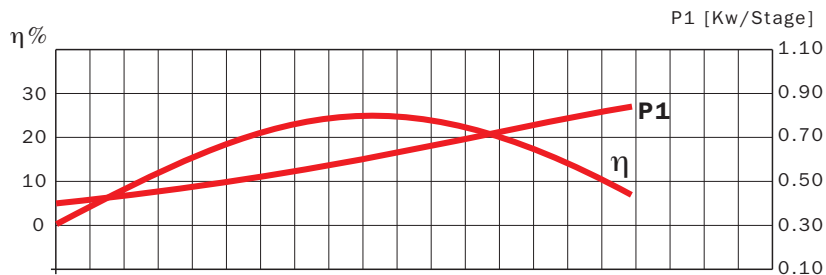
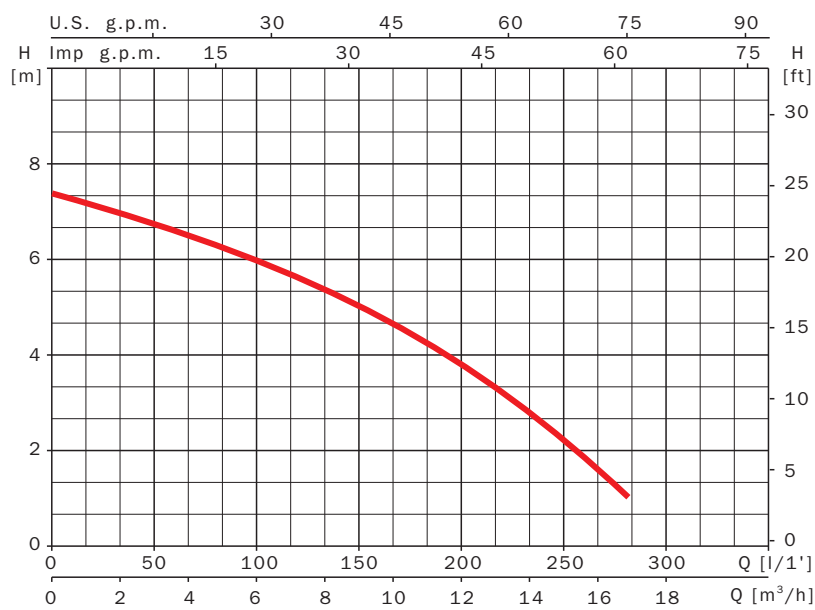

230 V 50 Hz	230/400 V 50 Hz	A			P1 (kW)		kW	HP	μF	l/min m³/h	25 1.5	50 3.0	100 6.0	125 7.5	150 9.0	200 12	250 15	280 16.8
		1~ 230 V	3~ 230 V	3~ 400 V	1~	3~												
Drainex 100M		3.4			0.75		0.75	1.0	12		7	6.7	5.9	5.5	5	3.7	2	1
Drainex 100M A		3.4			0.75		0.75	1.0	12		7	6.7	5.9	5.5	5	3.7	2	1