

Delta

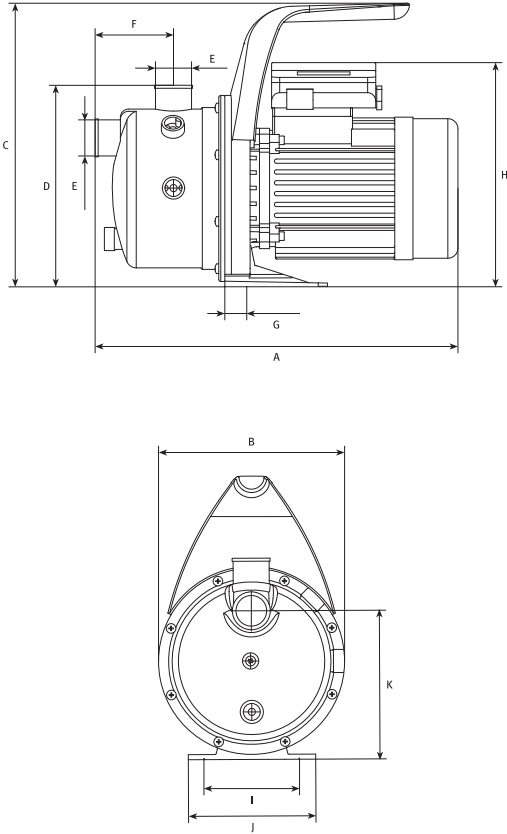

	A	B	C	D	E	F	G	H	I	J	K	Kg
Delta 505 M	336	184	280	200	1"	78	22	215	94	126	147	6,8
Delta 755 M	336	184	280	200	1"	78	22	215	94	126	147	7,3
Delta 1005 M	359	184	280	200	1"	78	22	225	94	126	147	9,6
Delta 1755 M	410	184	280	200	1"	125	22	225	94	126	145	12,1

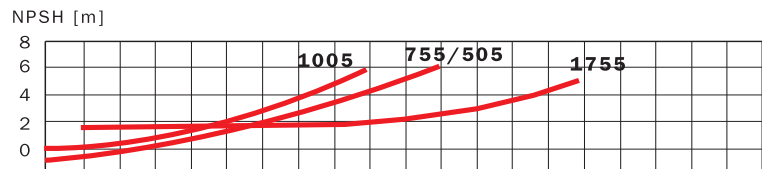
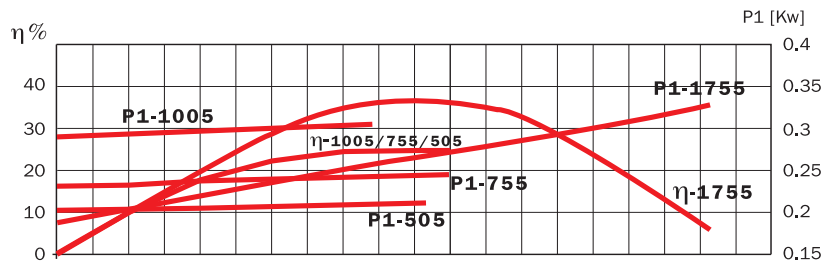
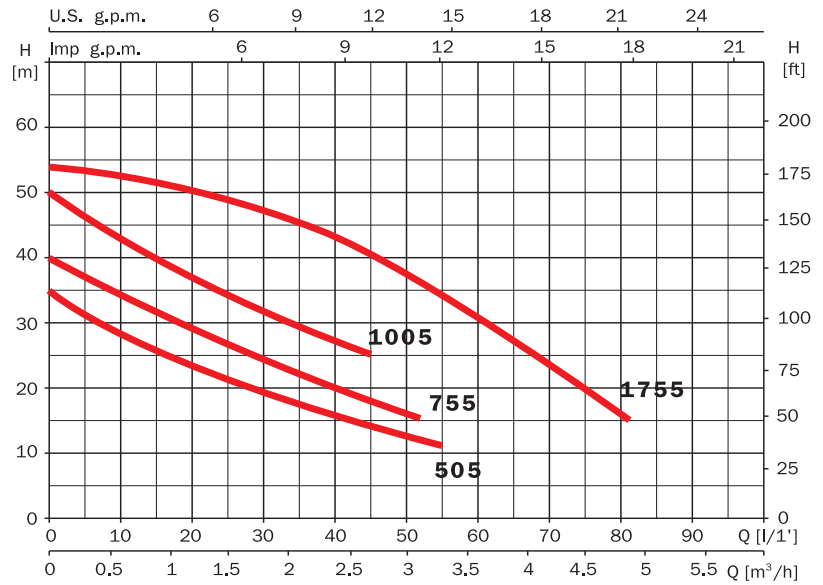

230 V 50 Hz	230/400 V 50 Hz	A			P1 (kW)		kW	HP	μF	I/1' m³/h	5 0.3	15 0.9	25 1.5	35 2.1	40 2.4	50 3.0	60 3.6	75 4.5
		1~ 230 V	3~ 230 V 400 V		1~	3~												
Delta 505M	Delta 505	2.8	2.2	1.2	0.6	0.6	0.37	0.5	12	33	26	22	18	17	13			
Delta 755M	Delta 755	3.4	2.6	1.3	0.8	0.8	0.5	0.75	12	37	32	27	23	21	17			
Delta 1005M	Delta 1005	4.8	3.3	1.9	1.0	1.0	0.75	1.0	16	47	40	34	29	27				
Delta 1755M	Delta 1755	5.5	3.8	2.1	1.2	1.2	0.75	1.0	16	57	55	51	47	44	38	32	21	